

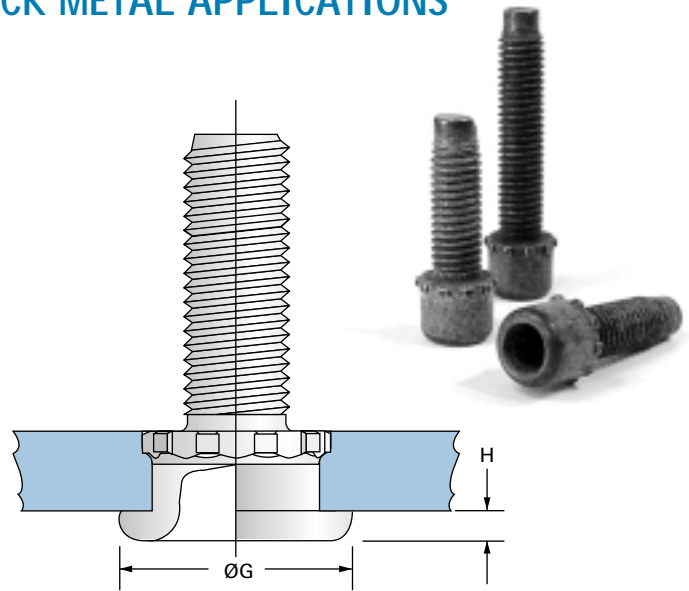

CS Series PierceForm® Stud

PIERCEFORM STUDS FOR THICK METAL APPLICATIONS

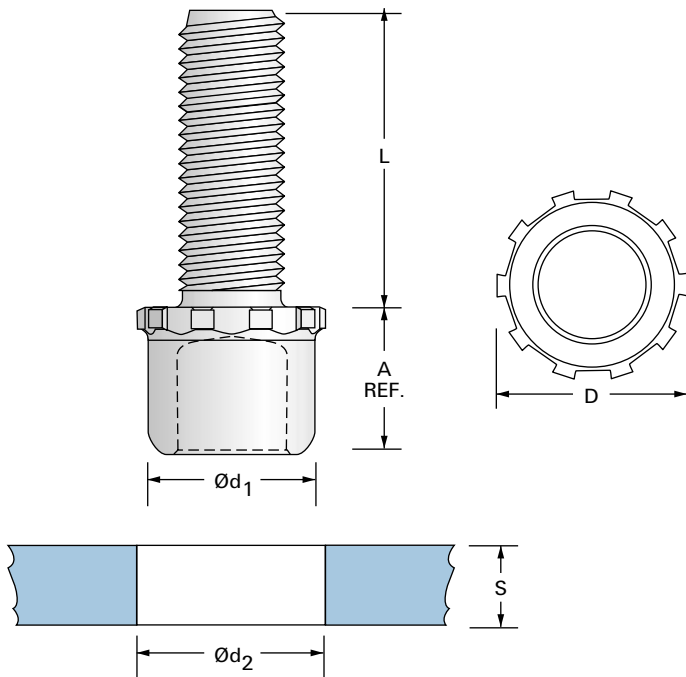

CS Series PierceForm Studs are property class 9.8 automatically installed, system-fed fasteners for installation in pre-pierced holes. Designed specifically for thick metal applications, these fasteners make a consistent mechanical attachment which provides a secure, permanent installation. Standard end configuration is the header point. Standard stud lengths (L) are: 16, 20, 25, and 30 mm. For applications where other end configurations or lengths are required, consult your sales representative.

PREFERRED STUD SIZE

STUD LENGTH L	CS6M	CS8M	CS1M
	PART NUMBERS		
16.0mm (0.69 in.) ±0.35mm (±0.01 in.)	CS6M160	—	—
20.0mm (0.79 in.) ±0.42mm (±0.02 in.)	CS6M200	CS8M200	CS1M200
25.0mm (0.98 in.) ±0.42mm (±0.02 in.)	CS6M250	CS8M250	CS1M250
30.0mm (1.18 in.) ±0.42mm (±0.02 in.)	CS6M300	CS8M300	CS1M300

STUD NUMBER	THREAD SIZE (6 g. TOL.)	A ±0.5mm (±.02 in.)	Ød ₁ ±0.5mm (±.02 in.)	Ød ₂ +0.1mm (±0.004 in.) -0.0mm (-0.00 in.)	D ±0.5mm (±.02 in.)	PANEL THICKNESS	ØG REF.	H REF.
						S		
CS6M	M6 x 1.0	8.50	8.70	8.90	9.90	2.00-2.74	12.9	2.3
						2.75-3.50		
						3.51-4.27		
						4.28-5.00		
CS8M	M8 x 1.25	10.00	11.18	11.40	12.65	2.25-3.00	16.6	2.8
						3.01-3.75		
						3.76-4.50		
						4.51-5.24		
						5.25-6.00		
CS1M	M10 x 1.5	12.00	14.00	15.00	16.13	2.50-3.18	20.9	3.3
						3.19-3.84		
						3.85-4.50		
						4.51-5.16		
						5.17-6.00		

CS6M PIERCEFORM STUD

Panel Thickness (mm)	Pull-Out Performance (kN)	Push-Through Performance (kN)	Torque Perform. w/o threaded post to apply torque (Nm)	Torque Perform. w/ threaded post to apply torque (Nm)
2.00	13.48	6.16	37.50	18.30
2.50	13.76	7.87	37.50	18.30
3.00	14.32	9.51	37.50	18.30
3.50	15.79	10.64	37.50	18.30
4.00	18.44	10.80	37.50	18.30
4.50	19.48	9.53	—	18.30
5.00	19.48	6.38	—	18.30

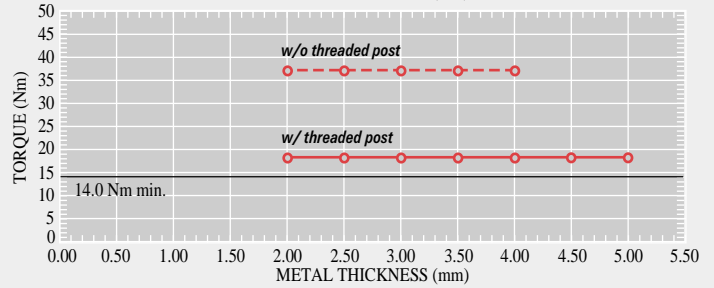
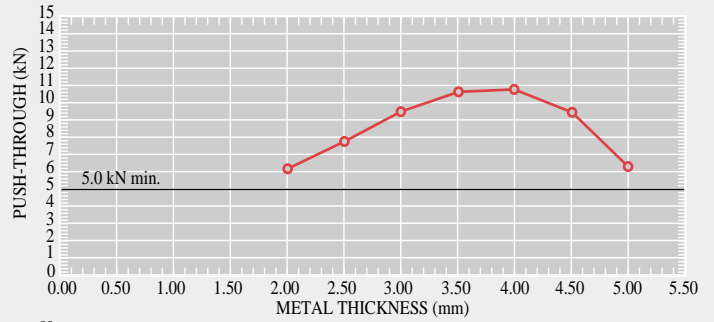
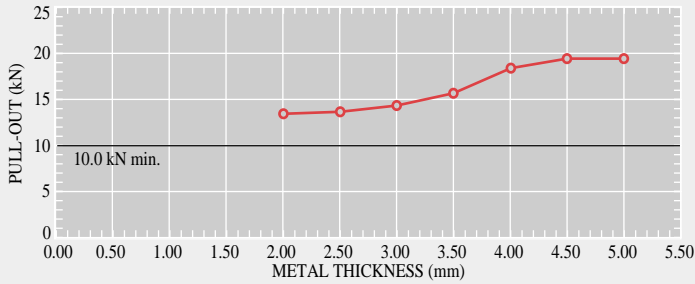

CS8M PIERCEFORM STUD

Panel Thickness (mm)	Pull-Out Performance (kN)	Push-Through Performance (kN)	Torque Perform. w/o threaded post to apply torque (Nm)	Torque Perform. w/ threaded post to apply torque (Nm)
2.25	18.36	8.02	60.00	44.50
2.50	18.43	9.58	60.00	44.50
3.00	19.16	12.32	60.00	44.50
3.50	21.22	14.57	60.00	44.50
4.00	24.19	16.33	60.00	44.50
4.50	26.88	17.60	—	44.50
5.00	27.92	18.38	—	44.50
5.50	26.31	18.67	—	44.50
6.00	21.99	18.46	—	44.50

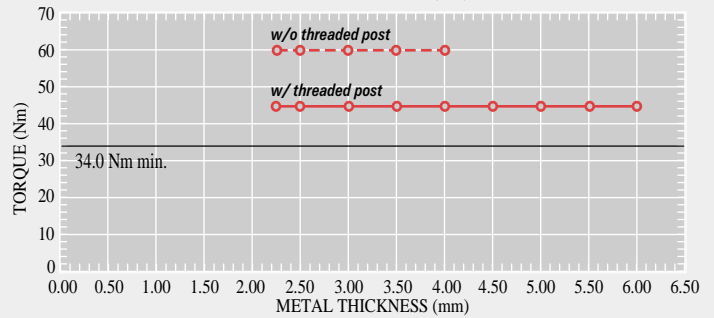
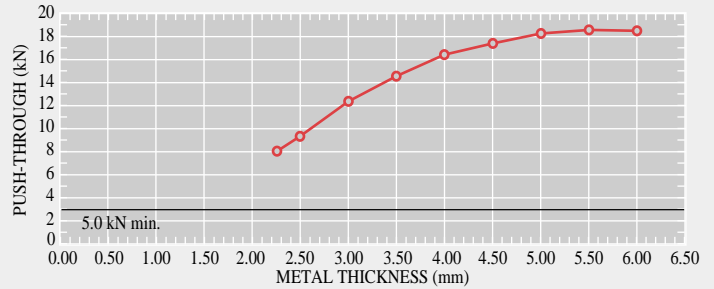
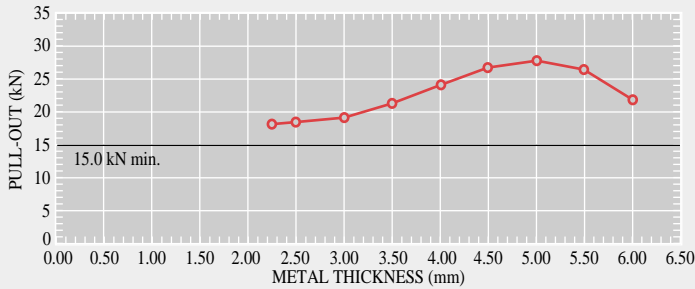

CS1M PIERCEFORM STUD

Panel Thickness (mm)	Pull-Out Performance (kN)	Push-Through Performance (kN)	Torque Perform. w/o threaded post to apply torque (Nm)	Torque Perform. w/ threaded post to apply torque (Nm)
2.50	20.41	8.34	90.00	84.50
3.00	21.27	10.51	90.00	84.50
3.50	22.05	13.72	90.00	84.50
4.00	24.77	17.17	90.00	84.50
4.50	32.14	20.03	90.00	84.50
5.00	39.10	21.50	—	84.50
5.50	42.86	20.75	—	84.50
6.00	44.30	16.98	—	78.60

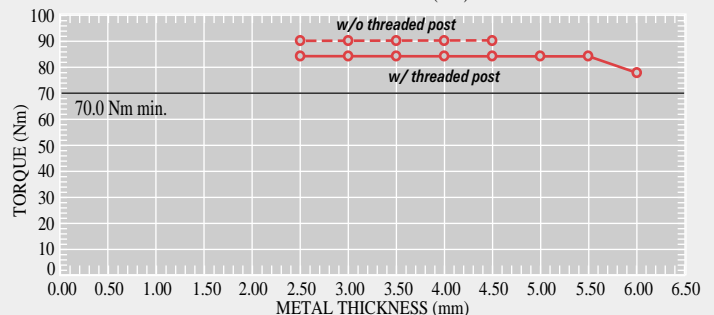
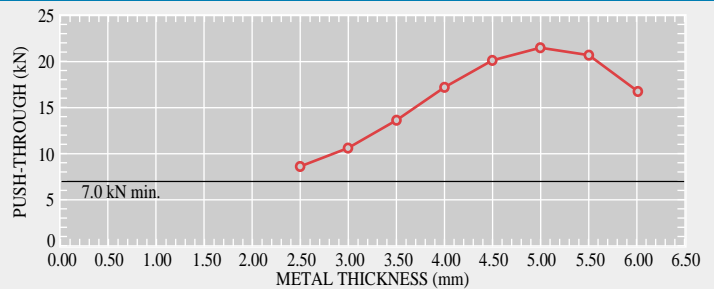
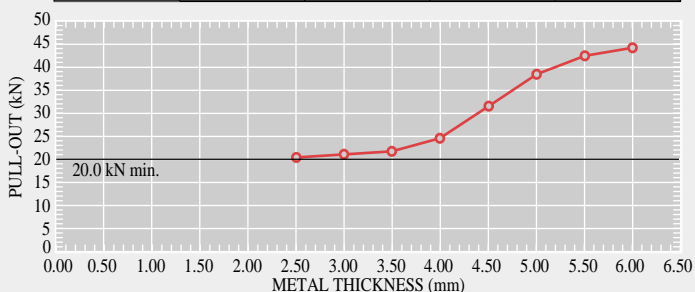

NOTE: ALL DATA ARE MEAN 3σ FOR STUDS INSTALLED IN 1008/1010 MILD STEEL.

Part Design Guidelines

CS Series PierceForm Studs are property class 9.8 automatically installed, system-fed fasteners for installation in pre-pierced holes.

Designed for thick metal applications, CS Series PierceForm Studs make a consistent mechanical attachment which provides a secure, permanent installation; standard stud lengths are 16, 20, 25 and 30mm; standard end configuration is the header point. All CS Series PierceForm Studs can be heat treated to property class 10.9 if your application requires. This can be accomplished using a shorter barrel on the stud.

CS Series PierceForm Studs may be installed in almost any panel material, of almost any shape, and in almost any multiple-pattern configuration, within the constraints shown below. **HOWEVER** – if you have a unique application not covered here, give us a call. We will help work out a solution with you.

APPLICATION IN SPECIAL MATERIALS.

For HSLA, stainless steel, aluminum, and/or plastic material, consult your representative for application assistance.

SELECT PROPER STUD.

Select according to tables found in this CS Series PierceForm Stud Specifications brochure.

USING TWO SHEETS OF METAL.

Total panel thickness not to exceed 90% of recommended thickness for CS Series PierceForm Stud metal range. For other panel materials, contact your representative.

SEALING APPLICATIONS.

Sealing is attained as an integral feature of the installation process by adding an adhesive to the barrel. Consult your representative for further details.

CRITICAL APPLICATIONS.

When extreme torque, stress, or environmental requirements exist, consult your representative for application assistance.

ACCURACY OF LOCATION.

In multiple stud installations the location of one stud to another will be within a diametral tolerance of 0.4 mm (0.015 in.).

WHEN A FORMING OPERATION FOLLOWS A STUD OPERATION.

Do not form part closer than 10 mm (0.39 in.) after stud is installed, as shown. For CS Series PierceForm Studs, part material formed into the clinch must not be disturbed. For closer spacing requirements, consult your representative.

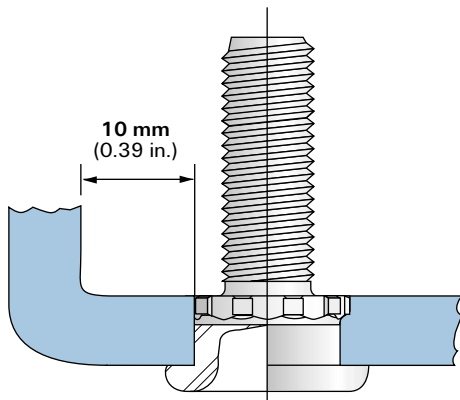

STUD EDGE TO PANEL EDGE DISTANCE.

Studs must not be installed closer to the edge of a panel than twice the thickness of the metal panel, as shown.

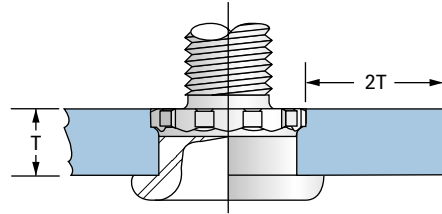

MINIMUM STUD SPACING (WITH STANDARD HEAD INSTALLATION TOOLING, RETAINERS MAY REQUIRE ALTERATION).

NOTE: Closer stud-to-stud distances may be achieved using altered standard and/or special tooling. Consult your representative.

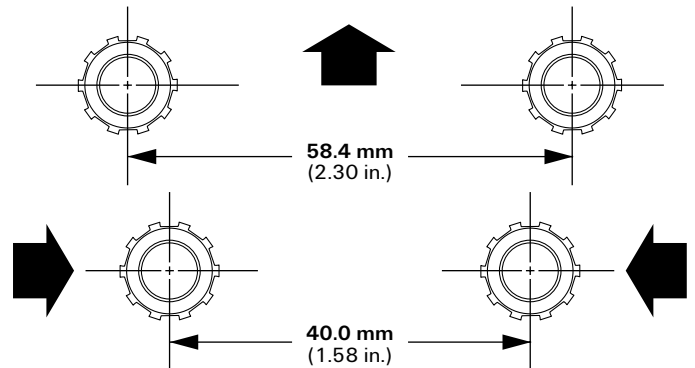

STUD TO FLANGE DISTANCES (WITH STANDARD INSTALLATION TOOLING).

Closer stud-to-flange distances may be achieved using altered standard and/or special tooling. Consult your representative.

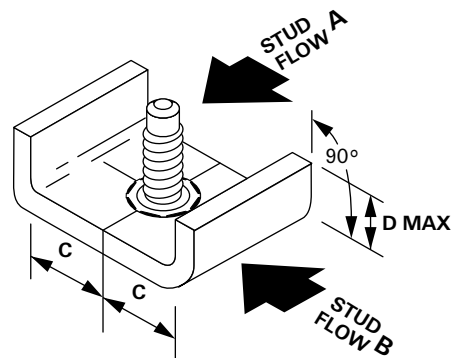

STUD FLOW	C	D
STUD FLOW A	26.5 mm	62.0 mm MAX
STUD FLOW B	20.0 mm	62.0 mm MAX

CS Series PierceForm Stud Installation. As easy as...

After aligning the CS Series PierceForm Stud installation head in the die it is necessary to establish the proper shut height with respect to the thickness of the panel being used. Use visual inspection of the stud installation as well as the Multifastener "Registry Marker" for establishing the proper shut height and as a continuous means of control installation integrity.

1 A CS Series PierceForm Stud is sent into the head via a stud feed system. The stud is held in position by the CS Series PierceForm Stud installation head until the customer part is in place, supported by the die button and retainer, underneath.

2 The head is partially closed with the use of a valve. Stud displaces part probe rod which activates sensor and signals system controller that stud is in position for installation.

3 As the die closes, the nose of the installation head contacts the metal panel and the plunger inside the head begins to push the CS Series PierceForm Stud through the pre-pierced hole in the panel.

4 When the CS Series PierceForm Stud has penetrated the panel it contacts the die button which forms the stud barrel into a 360° mechanical attachment onto the back of the metal panel. You now have a complete radial engagement of the stud to the panel and, as the die starts to open, another cycle is ready to start.

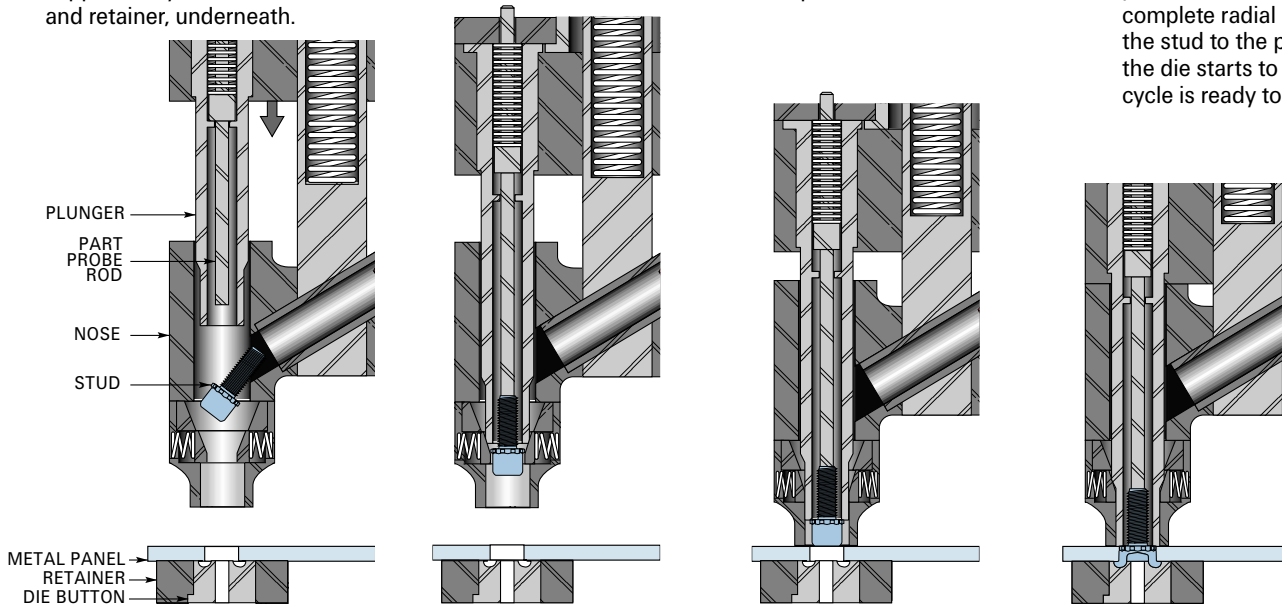

Operation

The CS Series PierceForm Stud feed system operates in unison with your press equipment to produce stud to panel attachments that are consistent time after time. For details concerning each component's setup and operation, plus maintenance and troubleshooting procedures, consult your representative.

